

## TGS 2600 - for the detection of Air Contaminants

### Features:

- \* Low power consumption
- \* High sensitivity to gaseous air contaminants
- \* Long life and low cost
- \* Uses simple electrical circuit
- \* Small size

The sensing element is comprised of a metal oxide semiconductor layer formed on an alumina substrate of a sensing chip together with an integrated heater. In the presence of a detectable gas, the sensor's conductivity increases depending on the gas concentration in the air. A simple electrical circuit can convert the change in conductivity to an output signal which corresponds to the gas concentration.

The **TGS 2600** has high sensitivity to low concentrations of gaseous air contaminants such as hydrogen and carbon monoxide which exist in cigarette smoke. The sensor can detect hydrogen at a level of several ppm. Figaro also offers a microprocessor (FIC02667) which contains special software for handling the sensor's signal for appliance control applications.

Due to miniaturization of the sensing chip, TGS 2600 requires a heater current of only 42mA and the device is housed in a standard TO-5 package.

The figure below represents typical sensitivity characteristics, all data having been gathered at standard test conditions (see reverse side of this sheet). The Y-axis is indicated as sensor resistance ratio ( $R_s/R_o$ ) which is defined as follows:

$R_s$  = Sensor resistance in displayed gases at various concentrations  
 $R_o$  = Sensor resistance in fresh air

### Applications:

- \* Air cleaners
- \* Ventilation control
- \* Air quality monitors

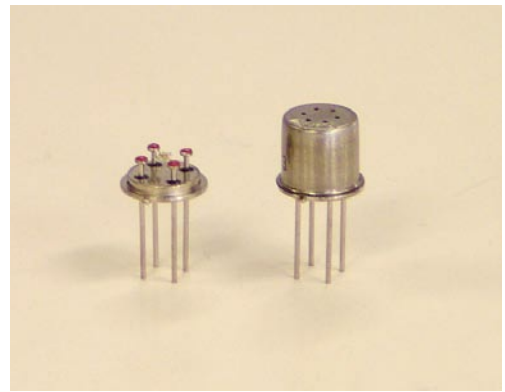

The figure below represents typical temperature and humidity dependency characteristics. Again, the Y-axis is indicated as sensor resistance ratio ( $R_s/R_o$ ), defined as follows:

$R_s$  = Sensor resistance in fresh air at various temperatures/humidities  
 $R_o$  = Sensor resistance in fresh air at 20°C and 65% R.H.

### Sensitivity Characteristics:

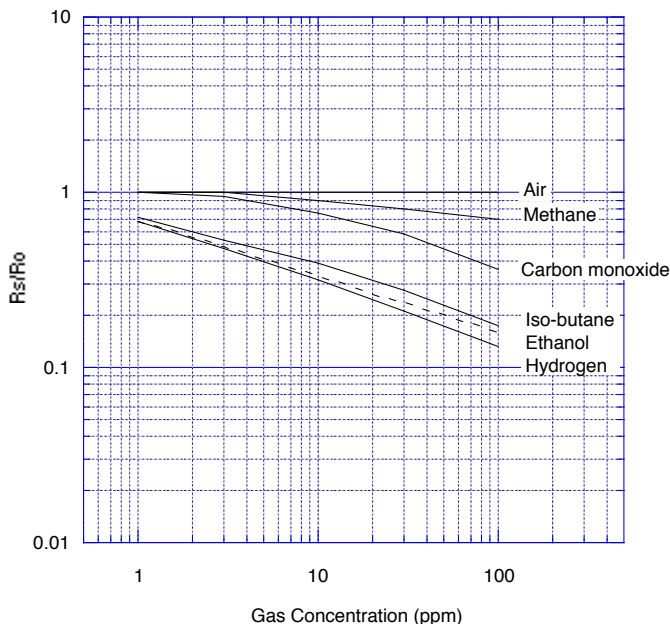

### Temperature/Humidity Dependency:

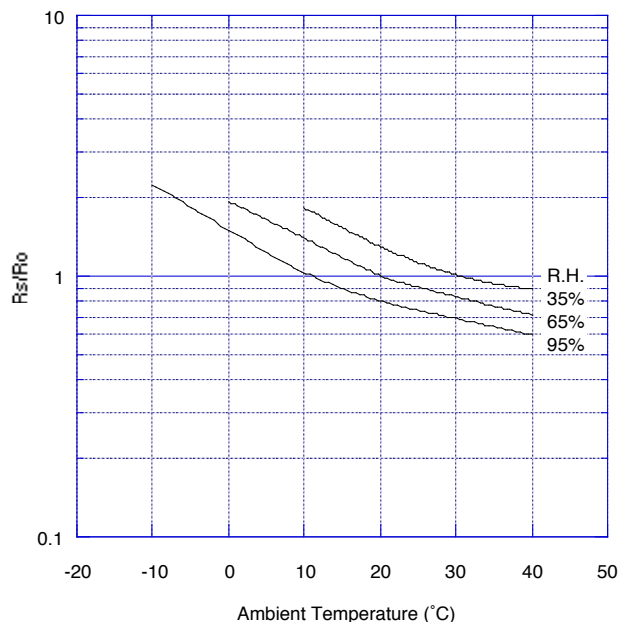

**Basic Measuring Circuit:**

The sensor requires two voltage inputs: heater voltage (V<sub>H</sub>) and circuit voltage (V<sub>C</sub>). The heater voltage (V<sub>H</sub>) is applied to the integrated heater in order to maintain the sensing element at a specific temperature which is optimal for sensing. Circuit voltage (V<sub>C</sub>) is applied to allow measurement of voltage (V<sub>out</sub>) across a load resistor (R<sub>L</sub>) which is connected in series with the sensor. DC voltage is required for the circuit

voltage since the sensor has a polarity. A common power supply circuit can be used for both V<sub>C</sub> and V<sub>H</sub> to fulfill the sensor's electrical requirements. The value of the load resistor (R<sub>L</sub>) should be chosen to optimize the alarm threshold value, keeping power consumption (P<sub>S</sub>) of the semiconductor below a limit of 15mW. Power consumption (P<sub>S</sub>) will be highest when the value of R<sub>S</sub> is equal to R<sub>L</sub> on exposure to gas.

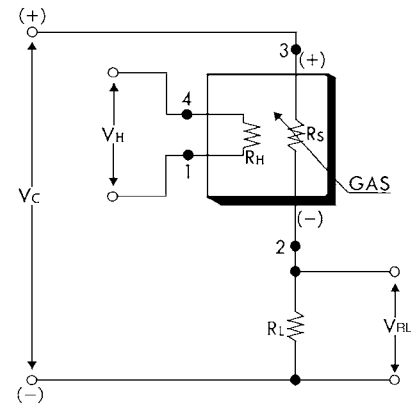

**Specifications:**

|   |   |  |  |
|---|---|--|--|
| Model number  |   | TGS 2600-B00   |  |
| Sensing element type                                      |   | D1   |  |
| Standard package  |   | TO-5 metal can   |  |
| Target gases  |   | Air contaminants   |  |
| Typical detection range                                   |   | 1 ~ 30 ppm of H <sub>2</sub>                                   |  |
| Standard circuit conditions                               | Heater voltage                                | V <sub>H</sub>   | 5.0±0.2V DC/AC   |
|   | Circuit voltage                               | V <sub>C</sub>   | 5.0±0.2V DC    P <sub>S</sub> ≤ 15mW                       |
|   | Load resistance                               | R <sub>L</sub>   | Variable    0.45kΩ min.                                    |
| Electrical characteristics under standard test conditions | Heater resistance                             | R <sub>H</sub>   | approx. 83Ω at room temp. (typical)                        |
|   | Heater current                                | I <sub>H</sub>   | 42±4mA   |
|   | Heater power consumption                      | P <sub>H</sub>   | 210mW    V <sub>H</sub> =5.0V DC                           |
|   | Sensor resistance                             | R <sub>S</sub>   | 10k~90kΩ in air  |
|   | Sensitivity (change ratio of R <sub>S</sub> ) |  | 0.3~0.6 $\frac{R_S(10\text{ppm of H}_2)}{R_S(\text{air})}$ |
| Standard test conditions                                  | Test gas conditions                           | normal air at 20±2°C, 65±5%RH                                  |  |
|   | Circuit conditions                            | V <sub>C</sub> = 5.0±0.01V DC<br>V <sub>H</sub> = 5.0±0.05V DC |  |
|   | Conditioning period before test               | 7 days   |  |

The value of power consumption (P<sub>S</sub>) can be calculated by utilizing the following formula:

$$P_S = \frac{(V_C - V_{out})^2}{R_S}$$

Sensor resistance (R<sub>S</sub>) is calculated with a measured value of V<sub>out</sub> by using the following formula:

$$R_S = \frac{V_C \times R_L}{V_{out}} - R_L$$

For information on warranty, please refer to Standard Terms and Conditions of Sale of Figaro USA Inc. All sensor characteristics shown in this brochure represent typical characteristics. Actual characteristics vary from sensor to sensor. The only characteristics warranted are those in the Specification table above.

**Structure and Dimensions:**

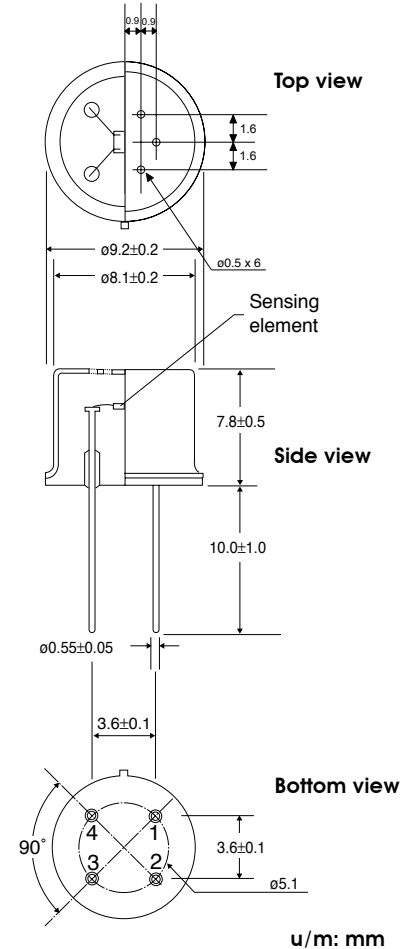

**Pin connection:**

- 1: Heater
- 2: Sensor electrode (-)
- 3: Sensor electrode (+)
- 4: Heater

**FIGARO USA, INC.**

121 S. Wilke Rd. Suite 300  
Arlington Heights, IL 60005  
Phone: (847)-832-1701  
Fax: (847)-832-1705  
e-mail: figarousa@figarosensor.com